

Detail view of nozzle's entry

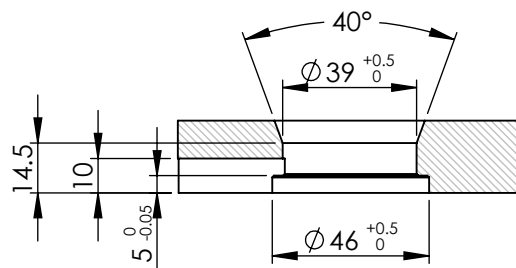

B : Detail view of injection ring

Isometric view of nozzle's placement in the mold

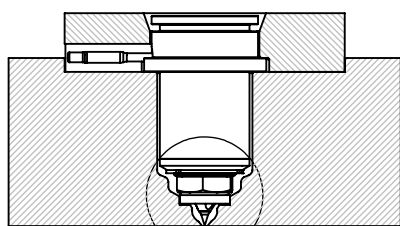
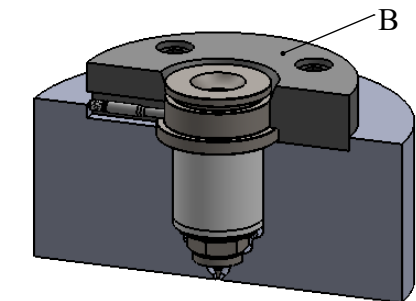

C

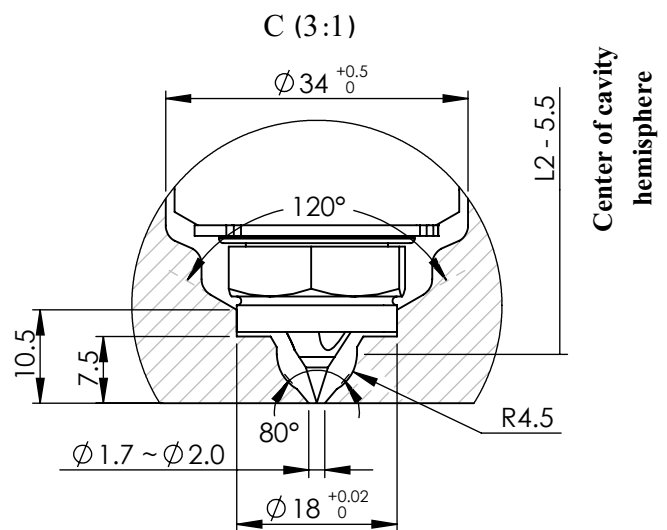

Detail view of nozzle's injection point

* There are 9 standard available sizes of this nozzle type as listed below.

** The "L1" length can be increased up to 250 mm by customer's order.

NOZZLE	S 44 G 103 *	L1 (mm) **	L2 (mm)	Heater's Power (W)
S 44 G 103 • 68		68	48	300
S 44 G 103 • 78		78	58	300-350
S 44 G 103 • 88		88	68	300-350
S 44 G 103 • 98		98	78	350-400
S 44 G 103 • 108		108	88	400-450
S 44 G 103 • 118		118	98	450-500
S 44 G 103 • 128		128	108	500-550
S 44 G 103 • 138		138	118	550-600
S 44 G 103 • 148		148	128	600-650

Title :	
NOZZLE	
Model :	Tel. No.: (+98)2122436853 Website : www.ihco.co
S 44 G 103 • L1	