

Detail view of nozzle's entry

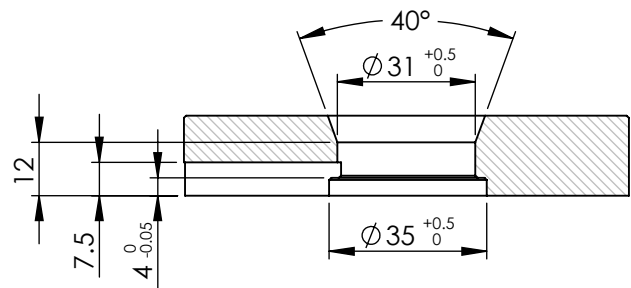

B : Detail view of injection ring

Isometric view of nozzle's placement in the mold

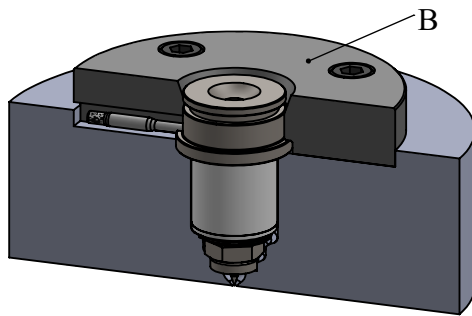
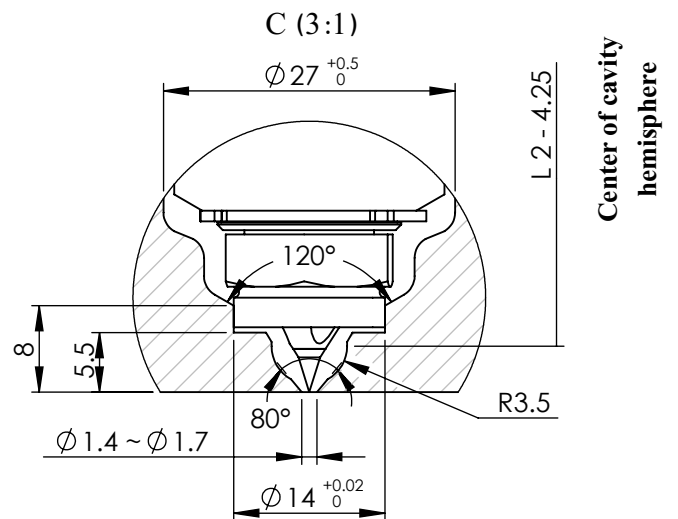
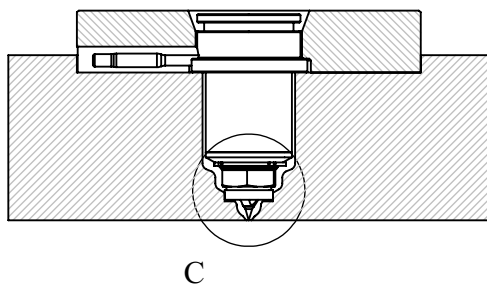

Detail view of nozzle's injection point

* There are 7 standard available sizes of this nozzle type as listed below.

** The "L1" length can be increased up to 150 mm by customer's order.

NOZZLE	S 34 G 103 *	L1 (mm) **	L2 (mm)	Heater's Power (W)
S 34 G 103 * 65		65	48	300-350
S 34 G 103 * 75		75	58	300-350
S 34 G 103 * 85		85	68	350-400
S 34 G 103 * 95		95	78	400-450
S 34 G 103 * 105		105	88	400-450
S 34 G 103 * 115		115	98	400-450
S 34 G 103 * 125		125	108	450-500

Title :	
NOZZLE	
Model :	Tel. No.: (+98)2122436853 Website : www.ihco.com
S 34 G 103 * L1	