

Detail view of nozzle's entry

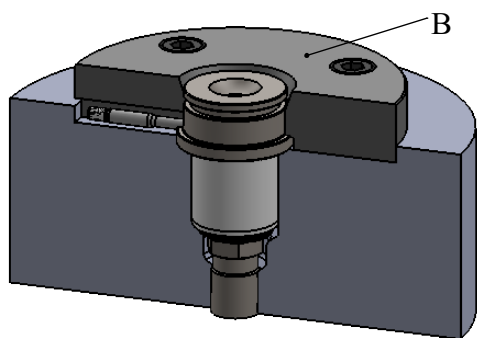

Isometric view of nozzle's placement in the mold

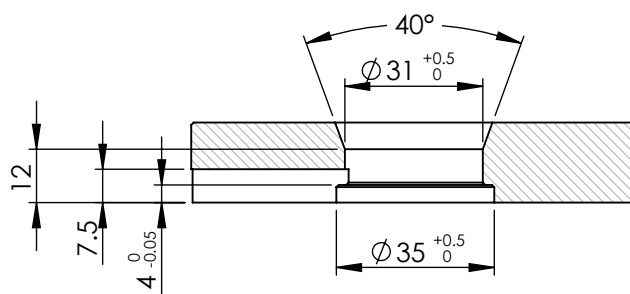

B : Detail view of injection ring

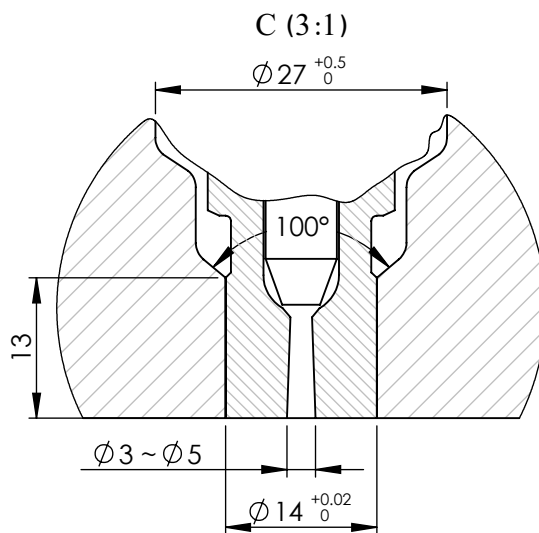
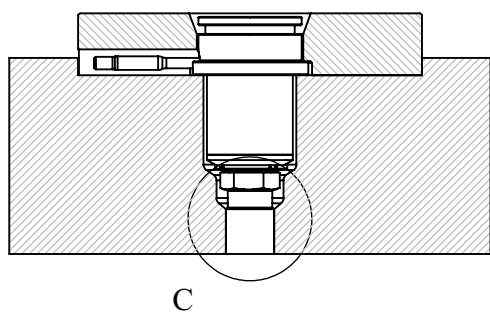

Detail view of nozzle's injection point

* There are 6 standard available sizes of this nozzle type as listed below.

** The "L1" length can be increased up to 150 mm by customer's order.

NOZZLE	S 34 C 102 *	L1 (mm) **	L2 (mm)	Heater's Power (W)
S 34 C 102 • 84		84	67	250-300
S 34 C 102 • 94		94	77	250-300
S 34 C 102 • 104		104	87	300-350
S 34 C 102 • 114		114	97	300-350
S 34 C 102 • 124		124	107	350-400
S 34 C 102 • 134		134	117	400

Title :	
NOZZLE	
Model :	Tel. No.: (+98)2122436853 Website : www.ihco.co
S 34 C 102 • L1	