

**Isometric view of nozzle's placement in the mold**

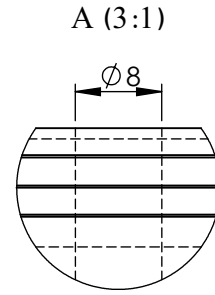

**Detail view of nozzle's entry**

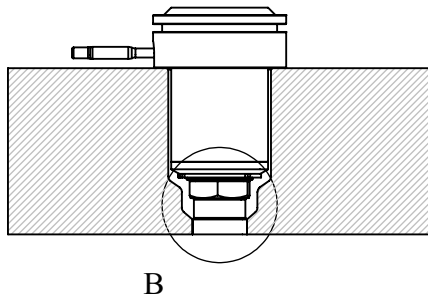
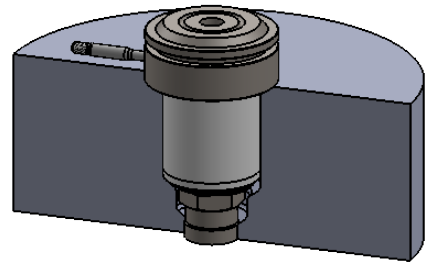

**B**

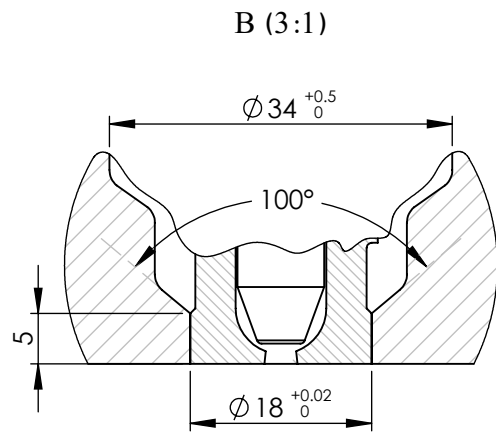

**Detail view of nozzle's injection point**

\* There are 9 standard available sizes of this nozzle type as listed below.

\*\* The "L1" length can be increased up to 250 mm by customer's order.

NOZZLE M 44 N 102 *	L1 (mm) **	L2 (mm)	Heater's Power (W)
M 44 N 102 • 68	68	48	250
M 44 N 102 • 78	78	58	250-300
M 44 N 102 • 88	88	68	300-350
M 44 N 102 • 98	98	78	300-350
M 44 N 102 • 108	108	88	350-400
M 44 N 102 • 118	118	98	400-450
M 44 N 102 • 128	128	108	450-500
M 44 N 102 • 138	138	118	550-600
M 44 N 102 • 148	148	128	550-600

Title :	
<b>NOZZLE</b>	
Model :	Tel. No.: (+98)2122436853 Website : <a href="http://www.ihco.co">www.ihco.co</a>
<b>M 44 N 102 • L1</b>	