

Isometric view of nozzle's placement in the mold

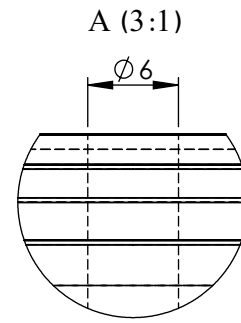

Detail view of nozzle's entry

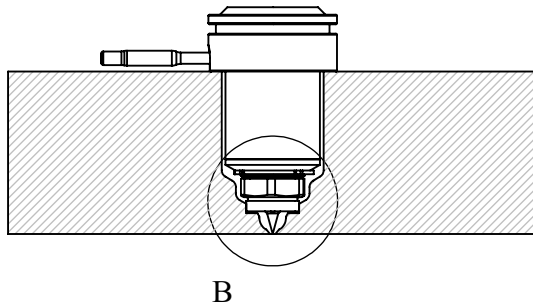
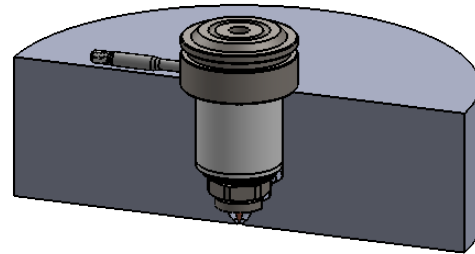

B

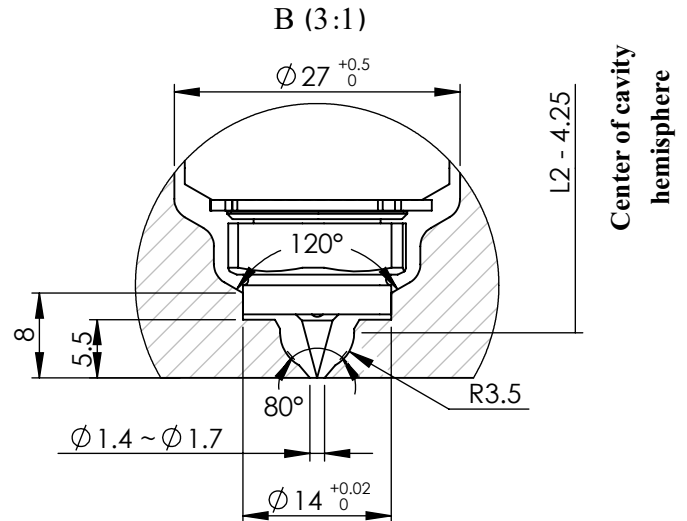

Detail view of nozzle's injection point

* There are 8 standard available sizes of this nozzle type as listed below.

** The "L1" length can be increased up to 150 mm by customer's order.

NOZZLE M 34 G 101 *	L1 (mm) **	L2 (mm)	Heater's Power (W)
M 34 G 101 • 55	55	38	200
M 34 G 101 • 65	65	48	200-250
M 34 G 101 • 75	75	58	250-300
M 34 G 101 • 85	85	68	250-300
M 34 G 101 • 95	95	78	300-350
M 34 G 101 • 105	105	88	300-350
M 34 G 101 • 115	115	98	350-400
M 34 G 101 • 125	125	108	400

Title :	
NOZZLE	
Model :	Tel. No.: (+98)2122436853 Website : www.ihco.co
M 34 G 101 • L1	